



1. Toušeňská s.r.o.

Sandblasting Machines

1. Toušeňská s.r.o. company has been on the market for over 20 years. Nevertheless our experience in the field exceeds 30 years.

Being manufacturers and suppliers, our assortment includes a wide range of products: from mobile sand blasting, manual blast cabinets, pneumatic blast room, up to specialized automatic machines. As far as standard devices are concerned, we pay special attention to user-friendly manipulation, quick maintenance, and variability. For more complex devices we prefer one-to-one approach from an initial draft to final realization. We also have feedback thanks to our extensive application centre. We provide consulting service for the right choice and construction of appropriate blasting device as well as for the right choice of blasting abrasives. Our products are implemented in the Czech Republic, EU member countries, and others.

In this catalog you can find detail information about our product line, which means basic data, complementary equipment and accessories, and area of use.

In most cases we are able to find a solution according to your particular demands .

For further information see our websites:

www.sandblastingmachines.eu/

www.balotinovani.com/en/

Please contact us via our **website form** or **mail**:

info@1tousenska.cz

Our address:

1. Toušeňská s.r.o.

Hlavní 91

25089 Lázně Toušeň CZ

Contend

Introduction	1
Contend	2
User-friendly system	3
Accessories	4
Manual Blasting Cabinets (boxes)	5
ITB 70	5
TB 90	6
TTB 90 with Turntable	7
TTB 90 with Roller Track	8
TB 120 standard	9
TB 120-VD with Rolling-out Turntable	10
TB 120T-ZV with Rolling-out Turtable and Trolley	11
TB 120B-ZV	11
ITB 120-GK (glass decoration)	13
TB 150	14
TB 150 with Rolling-out Turtable	15
TB 150 with Draw-through Openings	15
TB 150-ZV	16
TB 150-P	17
TB 200	18
Automatic Blast Devices	20
Control and Safety Elements	20
Tumble Blast Boxes	21
TB 1BP-AV Single Tumble Blast Machine	21
TB 2BP-AV Double Tumble Blast Machine	22
Carousel Blasting Machines	24
Carousel 1200-8	24
Carousel 1200-20	25
TB 225-RT Automatic Blast Cabinets with Turntable	26
SCM v.2 (plastic screw cleaning)	27
Pneumatic Blasting Rooms TBK	28
Combi Cabinets	28
TBK 1103	28
TBK 1104	29
Blasting Rooms with Full Floor Scraper Recovery System	30
Blasting Rooms with Screw Partial Recovery System	31
Blasting Rooms with Pneumatic Transport	32
Blasting Units with External Abrasive Delivery	34
ZTZ - Sandblasting Marker	36
Micro Blaster	37
Blast Pots	38
TTJ 10	38
TTJ 10-2	39
TTJ 10 with Irrigation Head	39
Dust Free Vacuum Blasters	40
High Volume Blasting Pots	41
TTJ 40	41
TTJ 100	41
TTJ 200	41
Dust Collectors	42
KOP1	42
OFJ1	42
OFJ2	43
OFJ3	43
OFJ6	43
Blast Media Survy	44

User-friendly System

We want to provide our customers with the latest professional devices which are efficient and flexible and are able to cover maximum of clients requests. At the same time we emphasize the fluency of the process and minimization of operators fatigue.

Our cabinets come with facilities that can speed up the process of cleaning and exchange of abrasive material. They also enable to alternate both injector and pressure systems and guarantee the highest comfort for workers.



double window enables quick inner-glass replacement

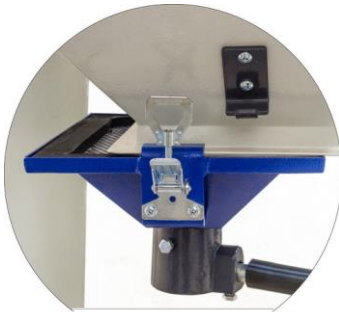

separable hopper bottom with sieve for easy cleaning



LED light situated outside the box

Our Facilities for Comfortable Work



rounded openings for hands



inner space without edges for quick cleaning

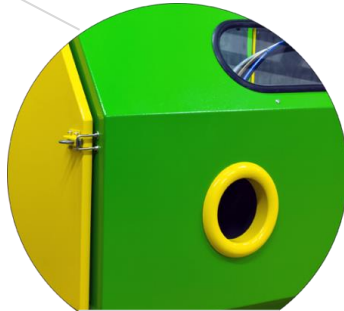

powder coating surface layer-colour on clients' request

We propose instalation of blowing gun inside the box, teleskopic nozzle holder, door lock at semi- and fully-automatic devices etc.

Complementary Equipment of Blasting Machines



stationary or rolling-out turntable for blasting of heavy products



telescopic nozzle holder for comfortable blasting of small things



additional cyclone separator



platform for easy installation of pressure system into big boxes

Particular accessories may be combine within one box. So it's possible to have a device equipped with turntable, draw-through openings, telescopic nozzle holder, cyclone etc.



microblaster for intensive spot-blasting



hinged window allowing frontal access to the box

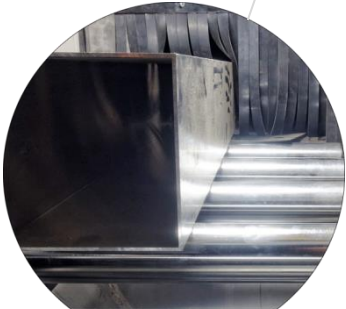

roller track for boxes with draw-through openings in doors



working site at the door - for more convenient blasting of large products



draw-through openings in doors for blasting of bars or other long objects

Manual Blast Cabinets (Boxes)

The standard sizes of manual blast cabinets range in sizes 70, 90, 120, 150, and 200 cm, in both pressure and in injector versions. Thought-out design of our products enables to alternate both systems according to actual needs.

A box in injector version is labelled ITB, in pressure version TTB and the number, which stands for its width, follows. The box can be equipped with lots of accessories which increase its efficiency. The most frequent equipment is given with particular cabinets.

ITB 70

Standard version for this box is the **injector** one.

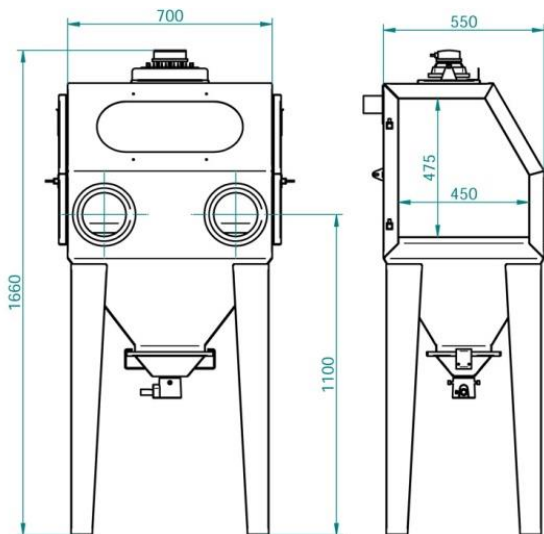

ITB 70 with movable platform

Inner dimensions (aprox)

width 700 mm
depth 500 mm
height 480 mm

Injector gun with nozzles 5/2,5 or 9/4 (jet n./injector n.) are installed in this system.

For these smaller cabinets an industrial vacuum cleaner is quite sufficient for exhaustion. But it's also possible to use central suction or professional three-phase dust collector.

Useful accessories:

Draw-through openings in doors, hinged front window, movable platform with locking wheels for placing the box and vacuum cleaner together (see the picture), supplementary cyclone, microblaster, telescopic nozzle holder.

Use:

Suitable for sandblasting and decoration small components, for tool shops, prototyping workshops, car services, glass-decorating, dental laboratories, museums, promotional items etc. Suitable for final metal treatment (satining) or pre-treatment for electro-plating (see www.balotinovani.com)

TB 90

This box is produced in both **pressure** and in **injector** versions. The lower part of the hopper is designed to allow fast alternation of both systems.

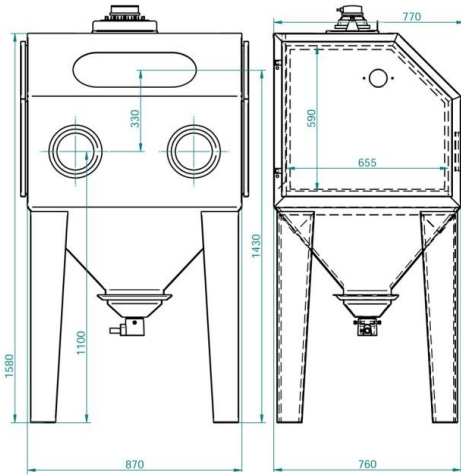

ITB 90 – injector version

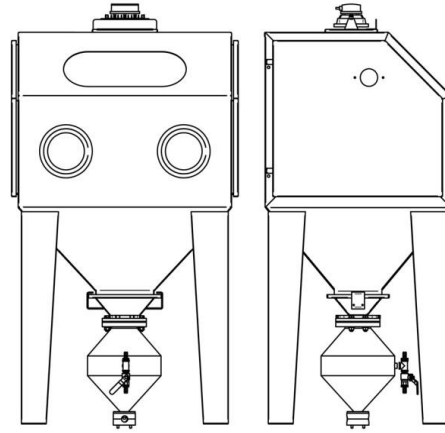

TTB 90 – Pressure version



ITB 90 with hinged window and
Micro Blaster

Inner dimensions (aprox)

width 900 mm
depth 650 mm
height 600 mm

For injector system we use nozzles: 5/2,5 mm, 9/4 mm or 15/7 (jet n./injector n.),
for pressure system: 4 -7 mm nozzle

For exhaustion it is possible to use professional three-phase dust collector or central suction.

Useful accessories:

Draw-through openings in doors (may be completed with a roller track), hinged front window, supplementary cyclone, microblaster, telescopic nozzle holder, stationary or rolling-out turntable (see TTB 90 and TTB 120)

Use

Suitable for sandblasting and decorating small components, for tool shops, prototyping workshops, car services, glass-decorating, dental laboratories, museums, production of promotional items etc.

The injector system is suitable for final metal treatment (satining) or pre-treatment for electro-plating (see www.balotinovani.com)

The pressure system is suitable for pre-treatment and is also powerful enough to remove old coatings.

TB 90 – Examples of its Versions

TTB 90 with Turntable

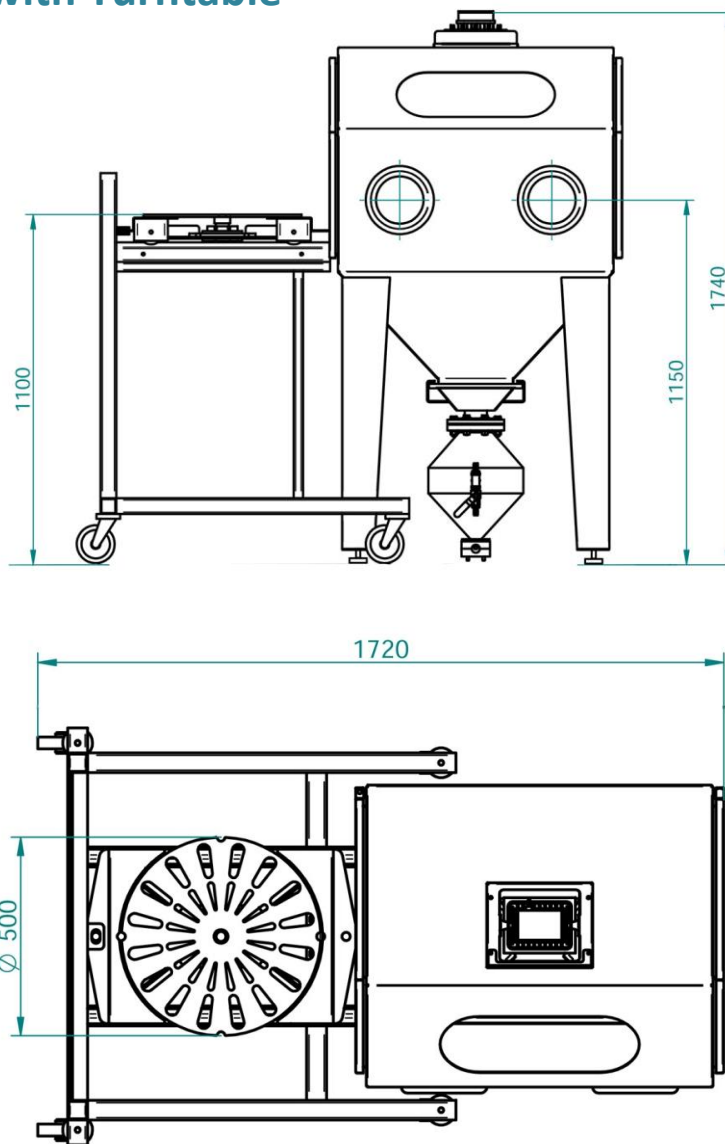

The picture shows a supporting trolley with locking. It's separable and so it's possible after the door is open to roll-out the turntable and move it to another place.

The stationary turntable or turntable without the trolley is optional as well (see ITB 120-VD example – the principle is the same).

Rolling-out turntable, eventually turntable with trolley comes advantageous when handling heavy weight, which is difficult to handle manually.

Note: Construction of turntable and trolley is adjusted according to size and weight of blasting products.

TTB 90 with Roller Track

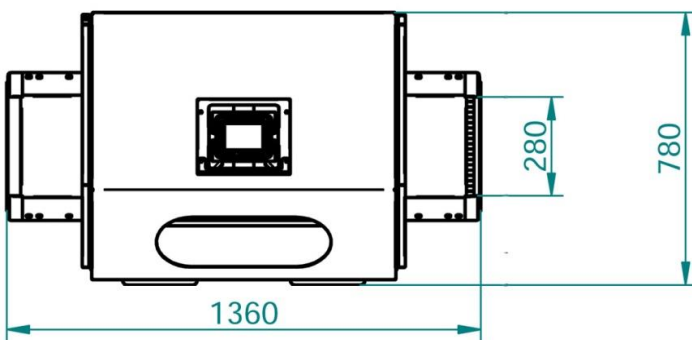
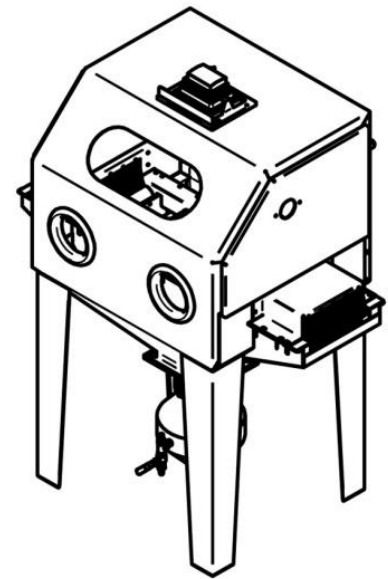
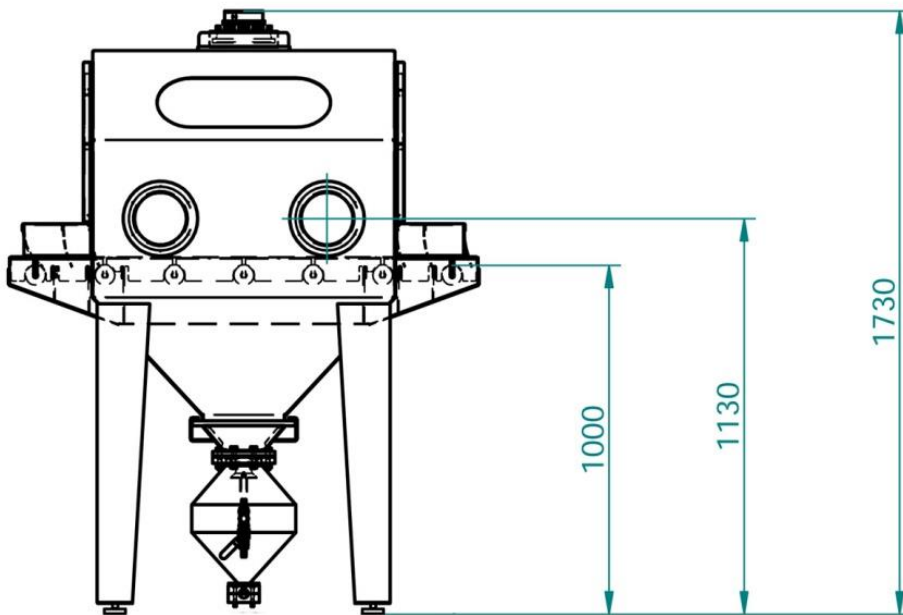

Roller track may be installed inside the box which is equipped with draw-through openings in doors. Rollers also may be placed in the openings. Size of the openings can vary according to customers' wish. There's TTB 90 in the picture but the track may be installed in other boxes, too. The roller-track isn't powered at standard manual blast cabinets.

Note: The roller track is designed according to size and weight of blasting products.

TB 120

This box is produced in both **pressure** and in **injector** versions. The lower part of the hopper is designed to allow fast alternation of both systems.

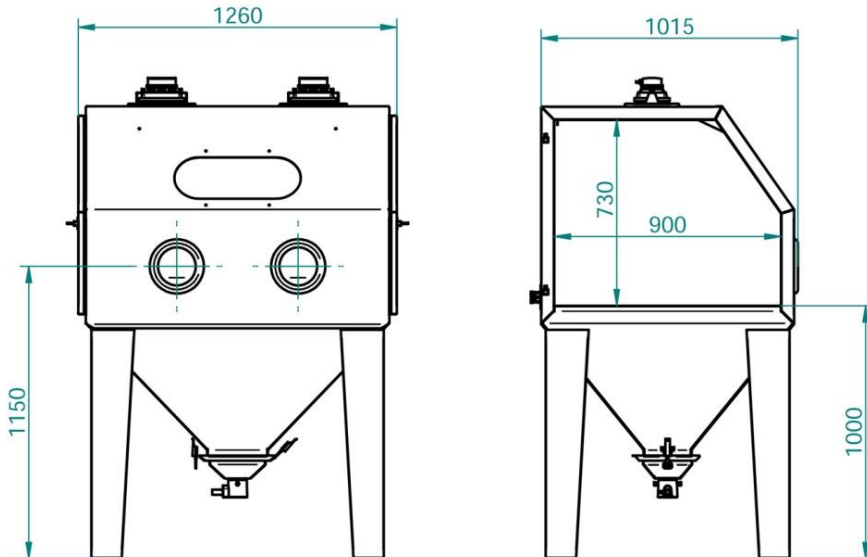

TB 120 verze Standard

Inner dimensions (aprox)

width 1200 mm
depth 950 mm
height 730 mm

For injector system we use nozzles: 5/2,5 mm, 9/4 mm or 15/7 (jet n./injector n.),
for pressure system: 4 -7 mm nozzle.

For exhaustion it is possible to use professional three-phase dust collector or central suction.

Useful accessories:

Draw-through openings in doors (may be completed with a roller track), supplementary cyclone, microblaster, telescopic nozzle holder, stationary or rolling-out turntable (see TTB 90 and TTB 120).

Use

Suitable for sandblasting and decorating of larger components, for industrial companies, tool shops, prototyping workshops, foundries, car services, glass-decorating, museums, production of promotional items etc.

The injector system is suitable for final metal treatment (satining) or pre-treatment for electro-plating (see www.balotinovani.com)

The pressure system is suitable for pre-treatment and is powerful enough to remove old coatings.

TB 120 – Examples of its Versions

TTB 120-VD with Rolling-out Turntable

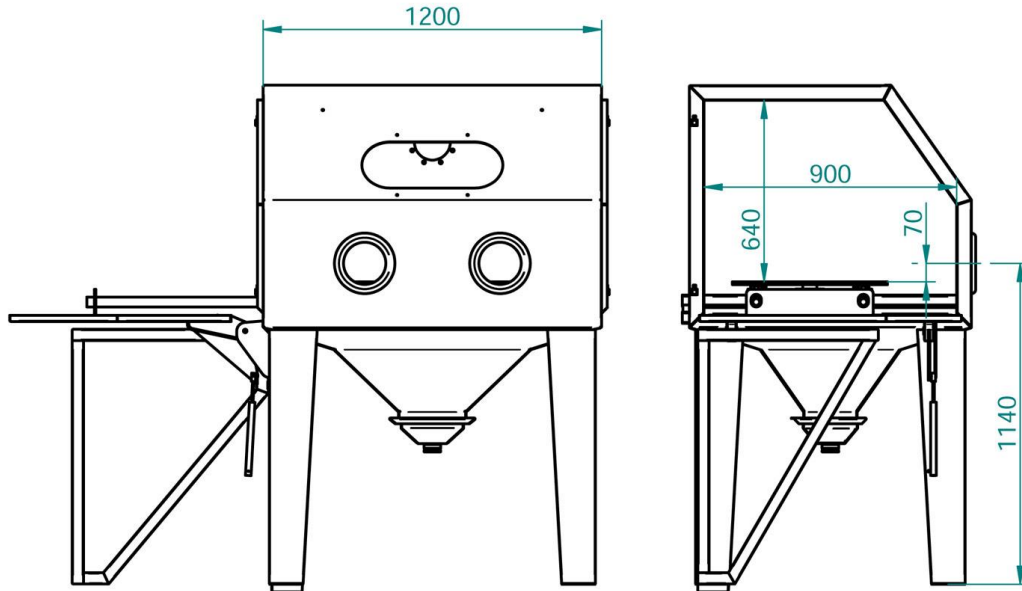

It is possible to roll out the turntable after the door is reclined onto supporting desk.

Other boxes TB (TB 70 –TB 200) may be also equipped with this type of turntable whichever the system (injector or pressure).

Note: The turntable is designed according to size and weight of blasting products.

ITB 120T-ZV with Rolling-out Turntable and Supporting Trolley

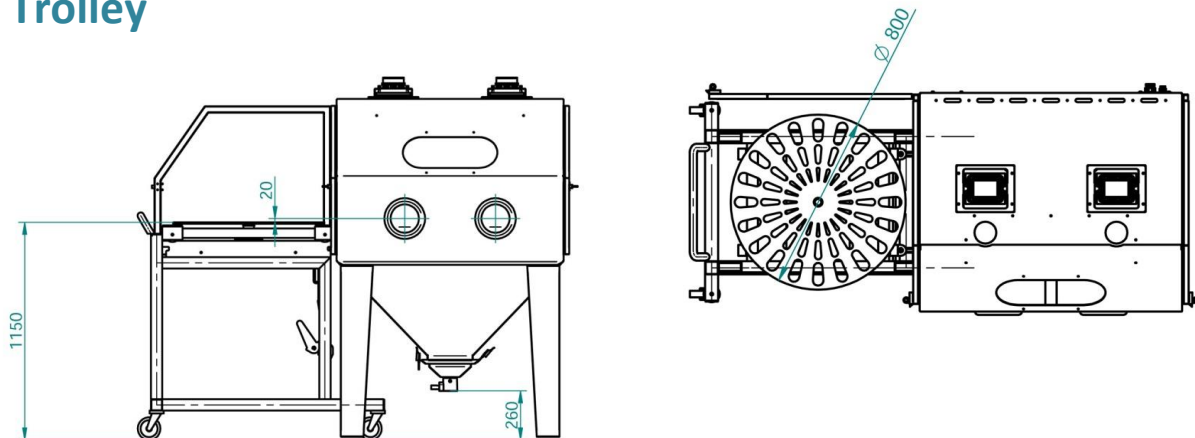

The picture shows a supporting trolley with locking. It's separable and so it's possible after the door is open to roll-out the turntable and move it to another place.

The stationary turntable or turntable without the trolley is optional as well (see ITB 120-VD example – the principle is the same).

Rolling-out turntable, eventually turntable with the trolley comes advantageous when handling heavy weight, which is difficult to handle manually.

Note: Construction of turntable and trolley is adjusted according to size and weight of blasting products.

TB 120B-ZV

Version of TB 120 with asymmetric manual workplace and semi-automatic tumble blasting machine.

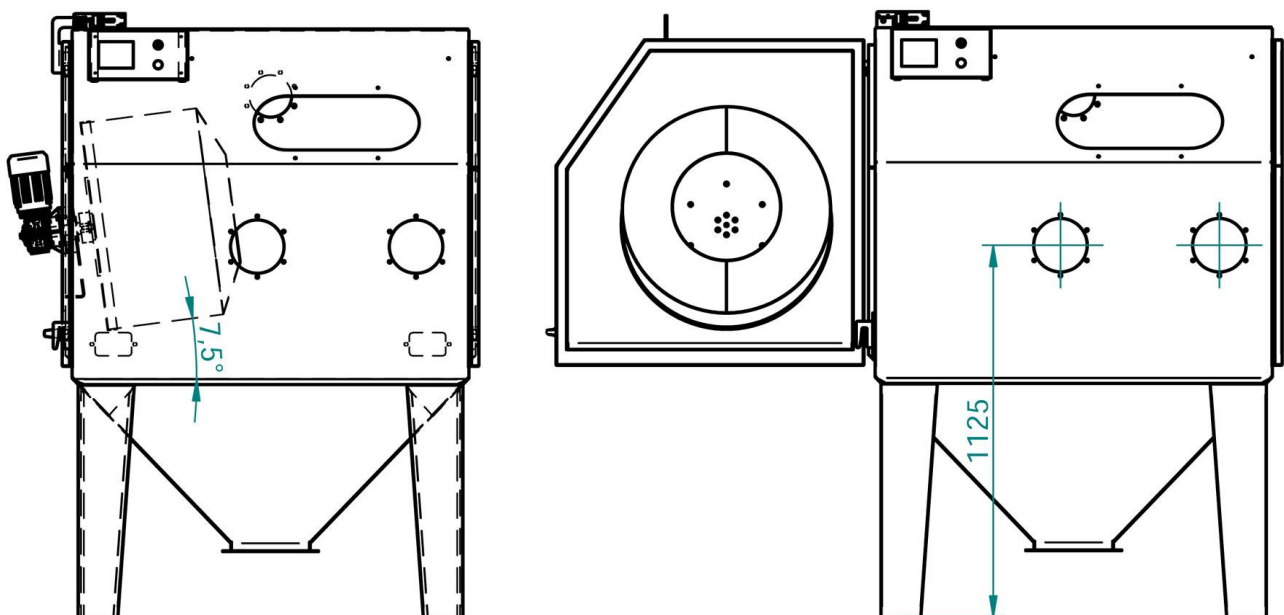

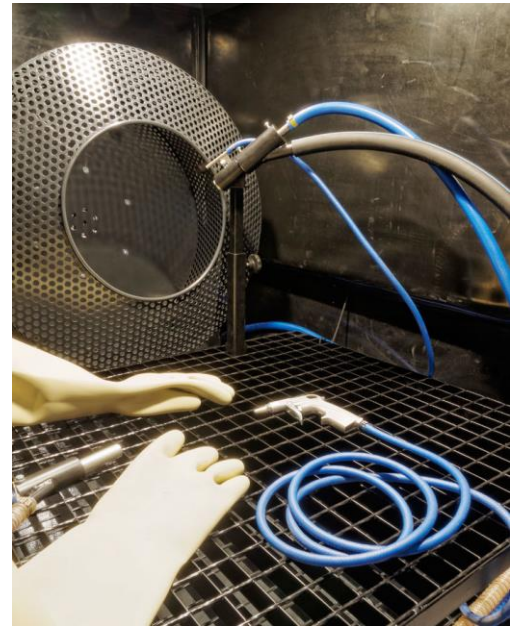

It is provided in **injector** version.

Manual workplace at this box is moved aside which allows to install the rotating basket into the door. The basket is fully controlled by a touch screen. Electronic control allows setting the time, number of cycles, time of air cleaning, run out, suction, direction and speed of the rotating basket for each type of a component. Requested settings for individual products can be saved as a unique program which is reloaded when need.

Furthermore, it is possible to set a wide variety of levels of authorization (operator, supervisor, maintenance...).

The rotating basket is fastened on the door of the cabinet. Industrial tumble blasters with tilting basket you can find on page 21 of the catalog.

The device is equipped with end-switch. Rotation of basket and inlet of compressed air are cut off immediately when the door is opened.

Manual section may be equipped with further accessories, i.e. telescopic nozzle holder for blasting smaller components, insertable stationary turntable etc.

Thanks its flexibility the cabin is suitable for wide application. It's used for cleaning 3D printers, surface treatment, pre-treatment for electro-plating, in prototyping workshops, in foundry etc.

ITB 120-GK

ITB 120-GK is a special device adapted for float-glass blasting. This box has pass-through slots sealed with brushes in both sides and the ceiling.

Various kinds of glass (vases, bottles, glasses etc) can be definitely blasted here, too.

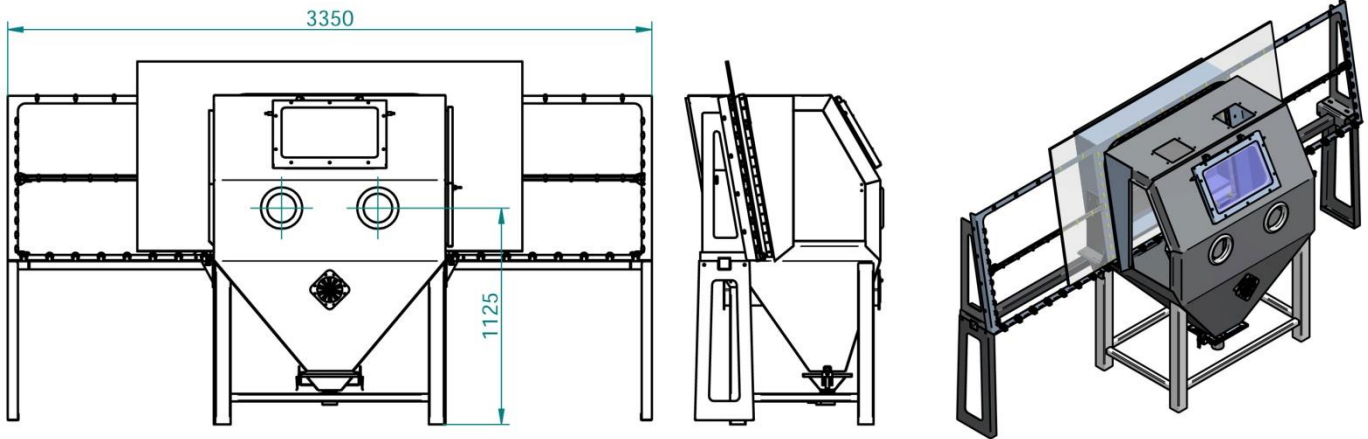

Inner space of the box



Passage through the box along on the roller-track

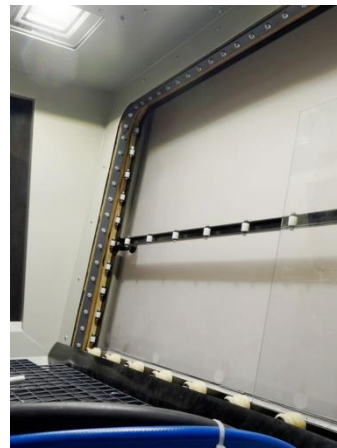

Ceiling light

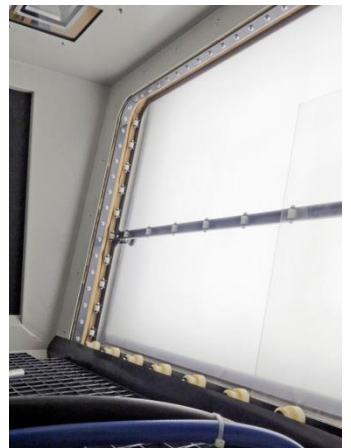

Backlighting rear wall

It's only provided in **injector** version.

Injector gun with nozzles 5/2,5 or 9/4 (jet n./injector n.) are installed in this system.

Approximate high of inner space is 800 mm but the ceiling slot allows to blast even larger sheets of glass, to turn them upside down and treat on their way back.

For checking the extent and homogeneity of blasting of larger sheets the **back wall is lightened**.

Ceiling light is installed for blasting of other kinds of glass.

Both lights can be used apart or together.

The glass is moved manually.

Design of this machine allows quick exchange of abrasive material when using different size of blast medium.

TB 150

This box is produced in both **pressure** and in **injector** versions. The lower part of the hopper is designed to allow fast alternation of both systems.

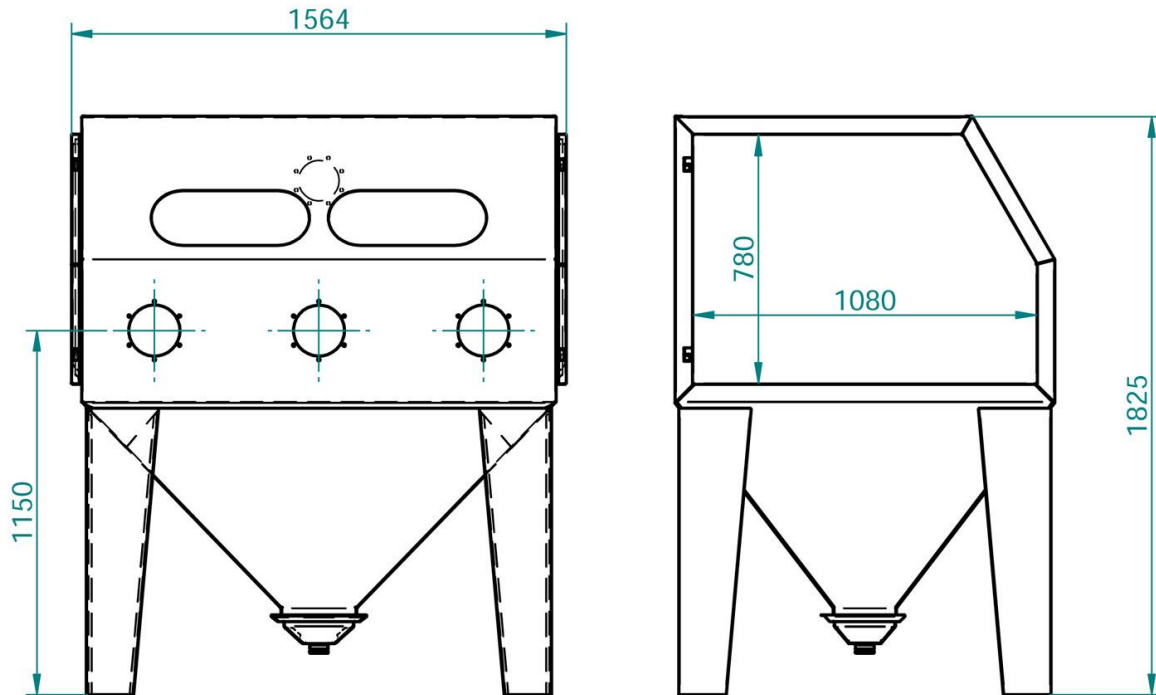

TB 120 verze Standard

Inner dimensions (aprox)

width	1500 mm
depth	1080 mm
height	780 mm

For injector system we use nozzles: 9/4 mm or 15/7 (jet n./injector n.),
for pressure system: 5 -7 mm nozzle.

Due to its large size this box has two working places. The middle opening for hands operates on both sections.

For exhaustion it's possible to use professional three-phase dust collector or central suction.

Useful accessories:

Draw-through openings in doors (may be completed with a roller track) or other working place in door, supplementary cyclone, microblaster, teleskopic nozzle holder, stationary or rolling-out turntable (see TTB 90 and TTB 120)

Use

Suitable for sandblasting and decoration larger components, for industrial companies, tool shops, prototyping workshops, foundries, car services, glass-decorating, museums etc.

The injector system is suitable for final metal treatment (satining) or pre-treatment for electro-plating (see www.balotinovani.com)

The pressure system is suitable for pre-treatment and is also powerful enough to remove old coatings.

TB 150 – Examples of its Versions

TB 150 with rolling-out turntable

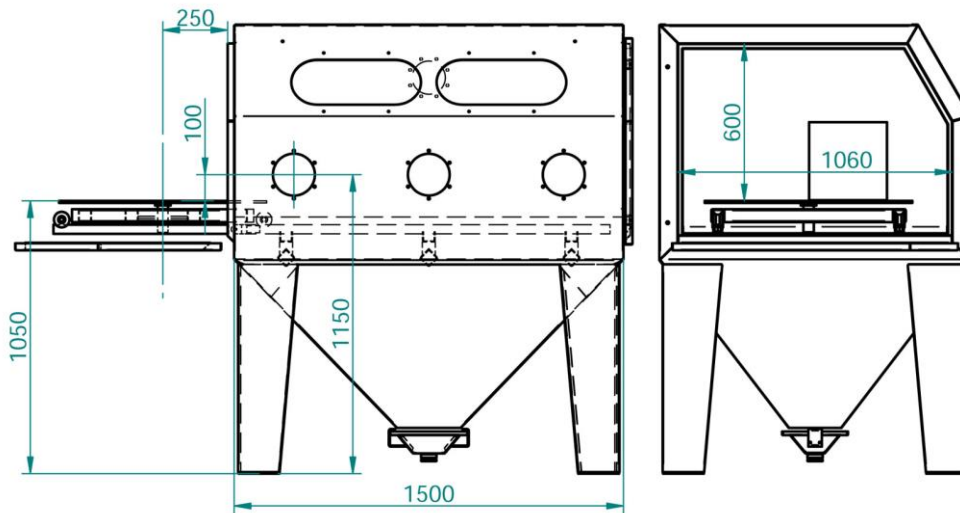

Rolling-out turntable comes advantageous when handling heavy weight, which is difficult to handle manually. A crane is possible to use for this purpose. Supporting trolley with locking or stationary turntable can be supplied as well.

TB 150 with pass-through openings

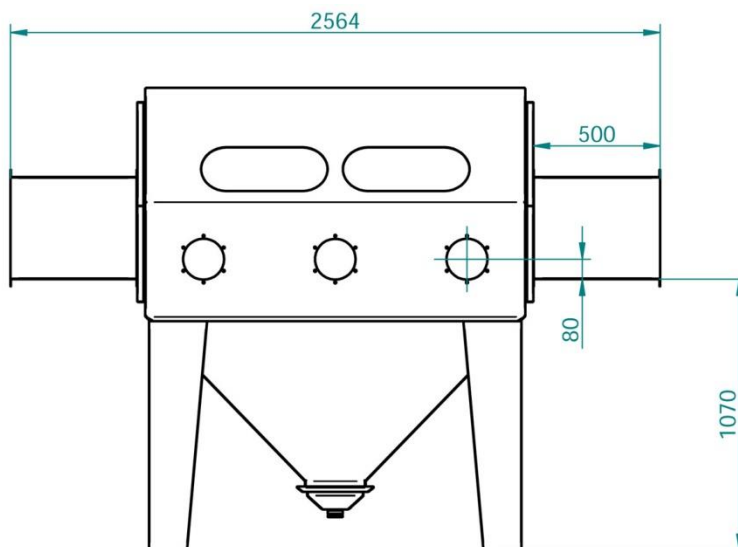

This box can be equipped with pass-through openings in doors and roller-track to make the passing-through easier.

TB 150-ZV

Installation of the pressure vessel directly under the hopper may be problematic with this size of box. Pressure vessel can be installed under the ground level if there is an assembly pit under the box. But working platform is used more often (see the picture) and standard box is fasten on it. It is also possible to extend legs of the box and place the platform and the box apart.

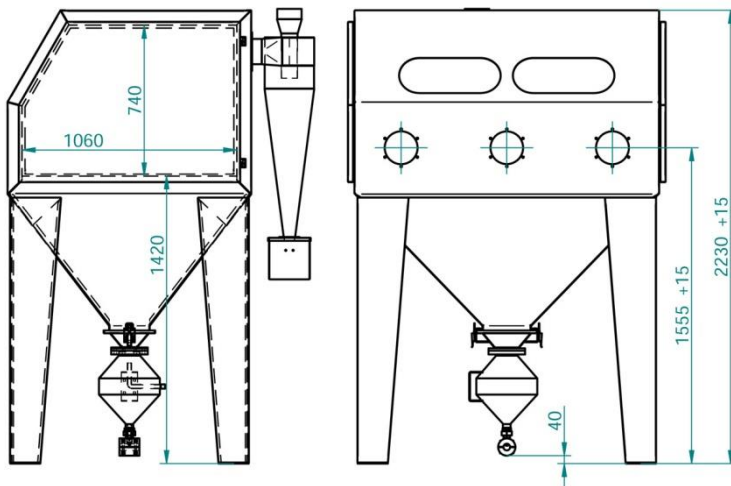

TB 150 ZV (box with extended legs)



TB 150 on the platform

The platform design depends on configuration and is specified for each particular device.

The next solution is to use **external abrasive transport unit**. This device is attached to the box and absorbs used material from the bottom of the hopper. Cleaned abrasive material is gathered in a reservoir and dosed automatically into the pressure sandblasting tank. This system is appropriate especially if the box is equipped with high-capacity pressure tank. It also allows continuous cleaning of abrasive and exact checking of its amount.

(see page 34 - external abrasive transport unit)

TB 150-P

A **square groundplan** of TB 150-P is a special one. It has **front sliding door** and is used for blasting products up to 1m in diameter. Products are inserted from the front. Usually it is equipped with a turntable or eventually with a trolley with locking. A minor door or a working place can be installed on the side.

This box is produced in both **pressure** and in **injector** versions.

The pressure version has to be equipped with **external abrasive transport unit**. (see p. 34)

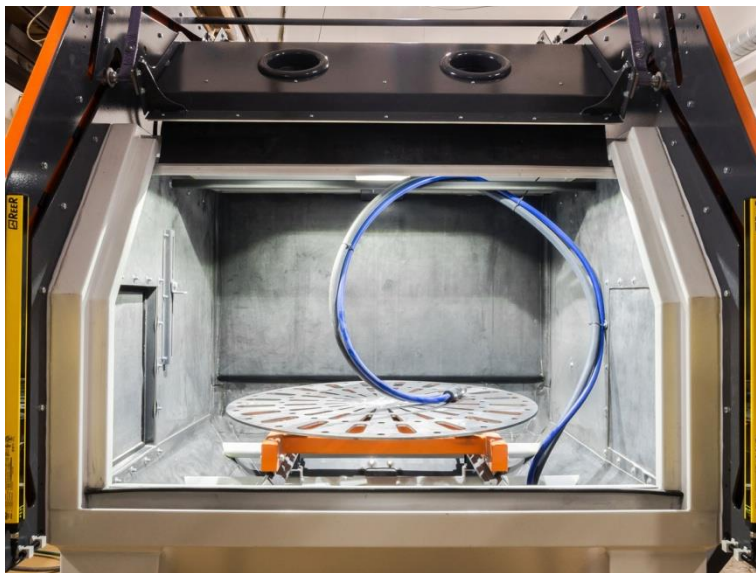
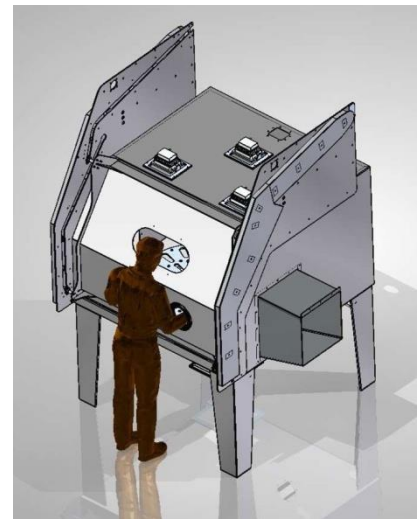
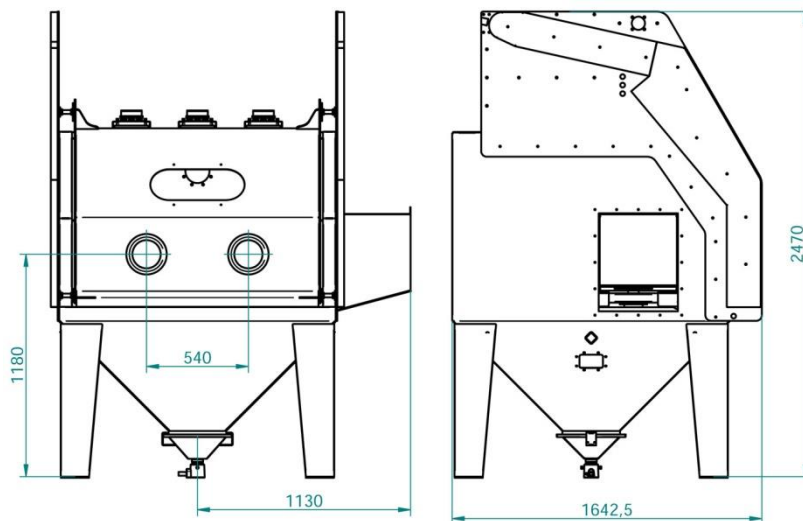

The box is equipped with safety elements like end switches in side doors, safety light barrier in front sliding door etc.

Note: The turntable and trolley are designed according to the size and the weight of blasting products.

TB 200

This box is produced in both **pressure** and in **injector** versions. The lower part of the hopper is designed to allow fast alternation of both systems.

Installation of the pressure vessel directly under the hopper may become problematic with this size of box.

If there is an assembly pit under the box, pressure vessel can be installed under the ground level. But working platform or the version with external abrasive transport unit is used more often. (see p.34).

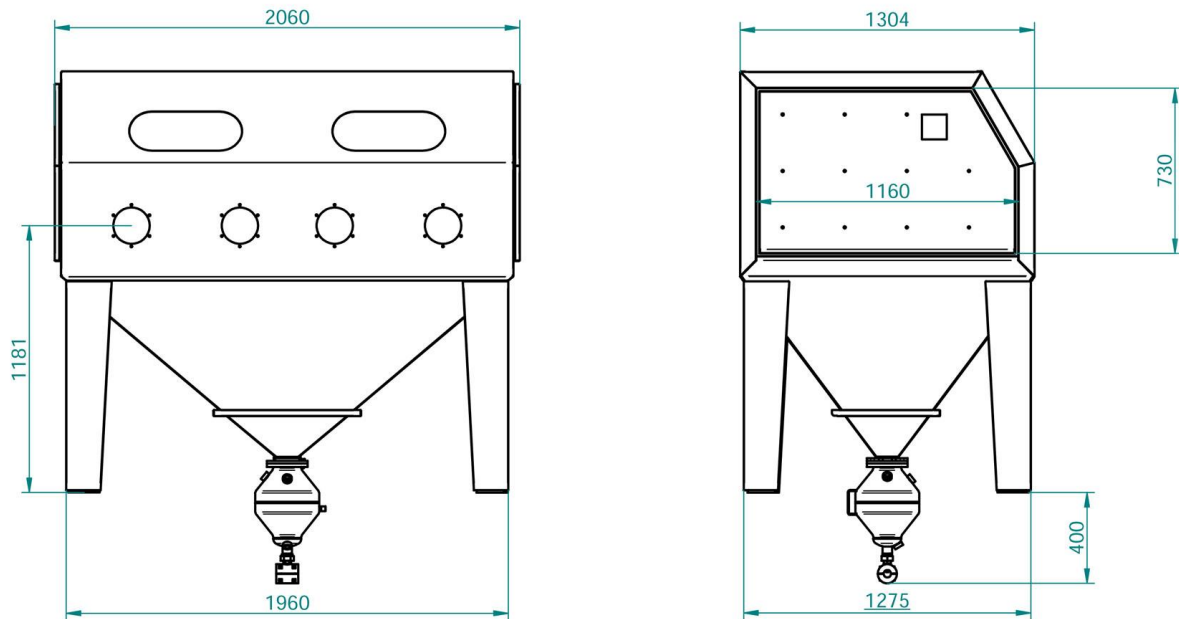

Inner dimensions (aprox)

width	2000 mm
depth	1200 mm
height	750 mm

For injector system we use nozzles: 9/4 mm or 15/7 (jet n./injector n.),

For pressure system: 5 -7 mm nozzle.

TB 200 Standard version

For exhaustion it's possible to use professional three-phase dust collector or central suction.

Due to its large size this box has two working places which allows larger products to be more easily blasted.

Useful accessories:

Draw-through openings in doors (may be completed with a roller track) or other working place in a door, supplementary cyclone, microblaster, teleskopic nozzle holder, stationary or rolling-out turntable. Particular components can be combined.

Use

Suitable for sandblasting and decoration larger components, for industrial companies, tool shops, prototyping workshops, foundries, car services, glass-decorating, museums etc.

The injector system is suitable for final metal treatment (satining) or pre-treatment for electro-plating (see www.balotinovani.com)

The pressure system is suitable for pre-treatment and is powerful enough to remove old coatings as well.

TB 200 – Examples of its Versions



TTB 200 with working platform, draw-through openings and cyclone



TTB 200 with working place in a door



TTB with external abrasive transport unit with 70-litre pressure vessel. Box is equipped with draw-through openings and rolling-out turntable with trolley.

Automatic Blast Devices

Automatic blast devices enables blasting in fully-automatic or semi-automatic mode. Such devices are practical especially for large-scale processing of smaller components and parts of similar shapes, or for processing products with high demands on precision or technological conditions.

In some cases, automatic blast box enables the operator to work on more machines simultaneously, or to perform other working activities.

These devices can be equipped with series of sophisticated control and safety elements according to their configuration.

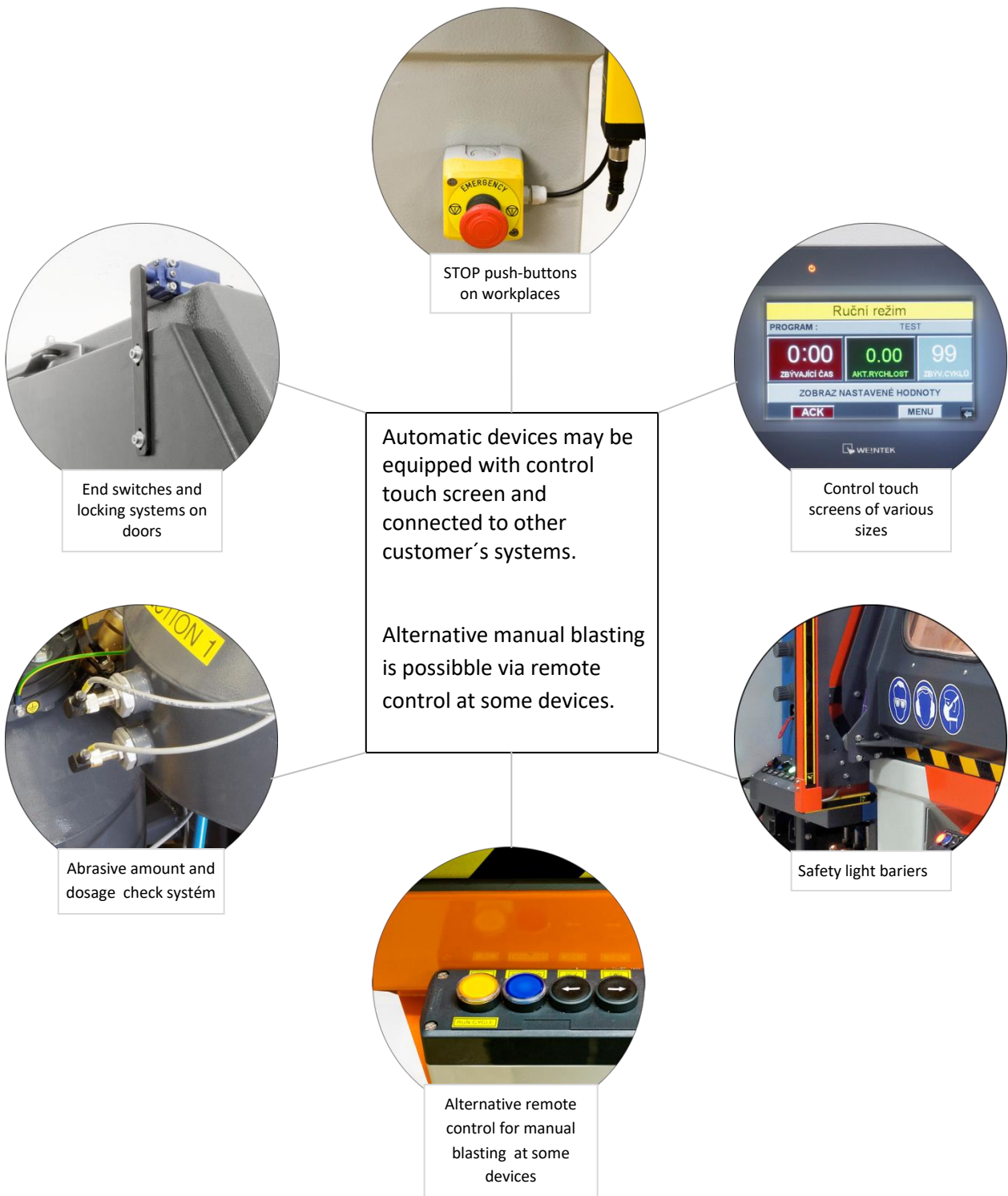

Tumble Blast Boxes

Tumble blast cabinets enable large-scale blasting of small components. Usually, they are supplied in **pressure** version. However, in special cases it is possible to provide our customers with **injector** version. Blasting process goes in fully-automatic mode. Electronic control allows setting the time, number of cycles, or rotation speed of the rotating basket in order to reach highest efficiency of the process.

The basket can be unloaded either manually using a lever or pneumatically using push buttons.

Tumble blast machines can be either of single section or two separate ones. The latter version noticeably raises work efficiency.

TB 1BP-AV Single Tumble Blast Machine

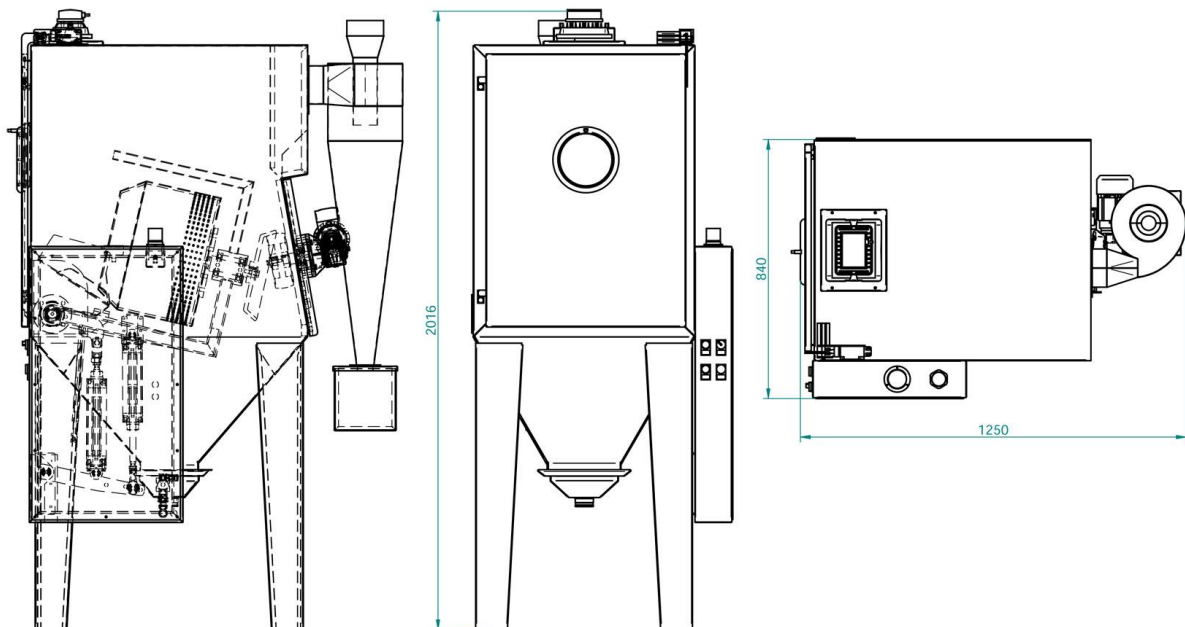

Outer dimensions (aprox)

width 840 mm

depth 1250 mm (including engine and additional cyclone)

height 2020 mm

optimal batch aprox 5-8 kg

Both **pressure** and **injector** versions are available. For pressure system 5 -7 mm nozzle is used.

The design of particular basket depends on type of blasted parts. It can be of polygon or round shape, made of mesh-work or steel plates. Basket rotates at an angle that can be set from 13° to 24°, speed and direction of rotation are also changable; so it's possible to reach optimal tumbling and maximal efficiency.

The most equipped version provides touch screen control which allows to set all specific parameters and save appropriate programs for individual products. All the programs can be simply loaded from memory.

TB 2BP-AV Double Tumble Blast Machine

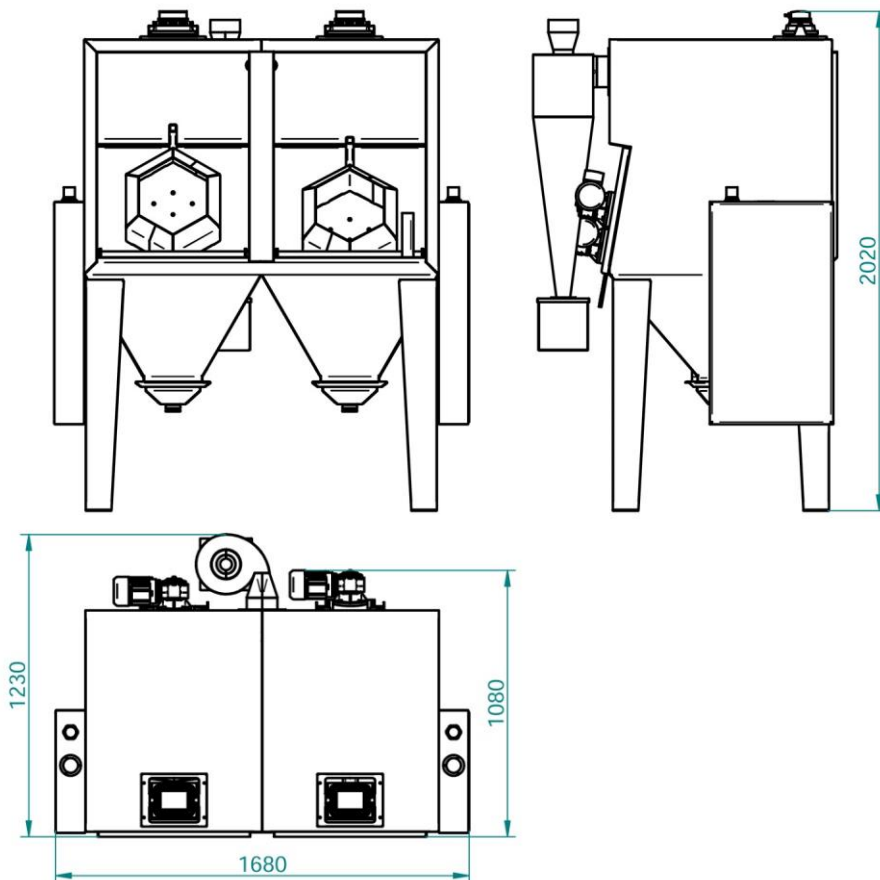

Outer dimensions (aprox)

width 1680 mm

depth 1250 mm (including engine and additional cyclone)

height 2020 mm

optimal batch aprox 5-8 kg

Both **pressure** and **injector** versions are available. Moreover you can combine both systems within one device.

For pressure system 5 - 7 mm nozzle is used.

Two separate sections noticeably raise work efficiency: while manipulation (loading-unloading) is happening in one section, blasting process is taking place in the other. The door may be equipped with window for checking.

The design of particular basket depends on type of blasted parts. It can be of polygon or round shape, made of mesh-work or steel plates. Basket rotates at an angle that can be set from 13° to 24°, speed and direction of rotation are also changeable; so it's possible to reach optimal tumbling and maximum efficiency.

Tumble blasting machines are produced in several versions according to both manipulation and control. The basket may be unloaded either manually (using a lever) or pneumatically (using a push button).

The most equipped version provides touch screen control which allows to set all specific parameters and save appropriate programs for individual products. All the programs can be simply loaded from memory.



Double Tumble Blast Machine with a lever (manual unloading)



Example of basket shape



Single Tumble Blast Machine with a touch screen (pneumatic unloading)



Double Tumble Blast Machine with a touch screen (pneumatic unloading)



We also produce combined semi-automatic tumble blast machine **TB 120B-ZV** which is described in this catalog p.11.

Carousel Blasting Machines

Carousel blasting machines are suitable for large-capacity blasting of rotary components. An operator only inserts workpieces into individual satellites and later takes them out. The actual process is fully automatic, running according given parameters. Number of nozzles is determined by the shape and requested capacity. They can be either stationary or movable. Touch screen control allows to set specific parameters, save appropriate program and load it from memory when need. Setting authorization (operator, supervisor, maintenance...) is possible, too.

Examples

Carousel 1200-8

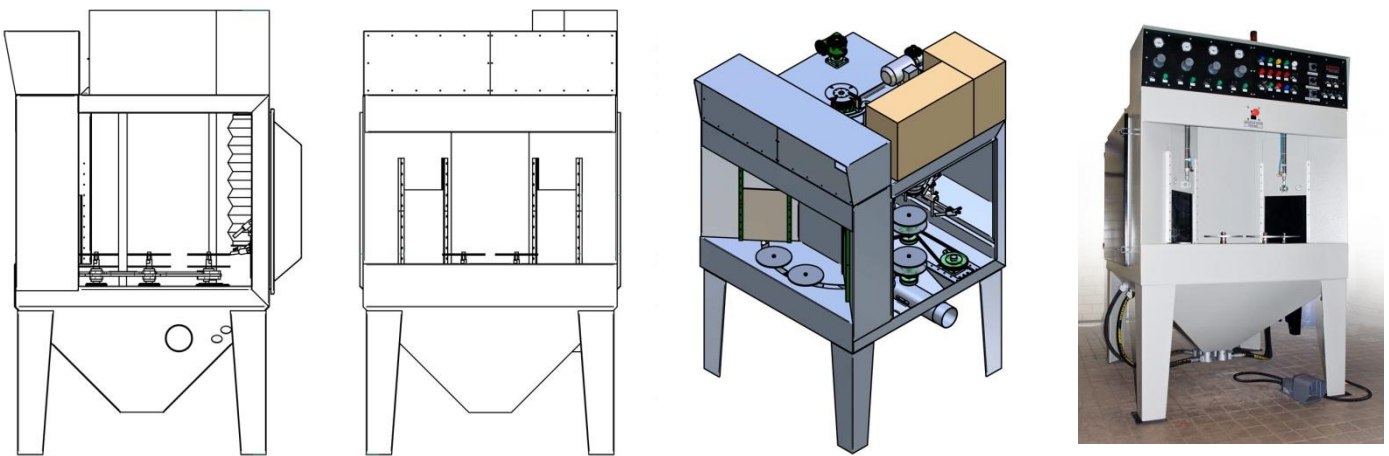

Outer dimensions (aprox)
width 1200 mm
depth 1400 mm
height 2010 mm

It is provided in **injector** version.

This device is equipped with eight planetary stations. An operator only inserts and takes out blasted workpieces. The pieces automatically move into the box for processing: they rotate at a set speed round posts where nozzles work. The nozzles vary in number and installation (stationary or movable).

It has front working place. The door allows easy entry to the cabin (for maintaining or setting) and it can be placed either on the sides or at the back.

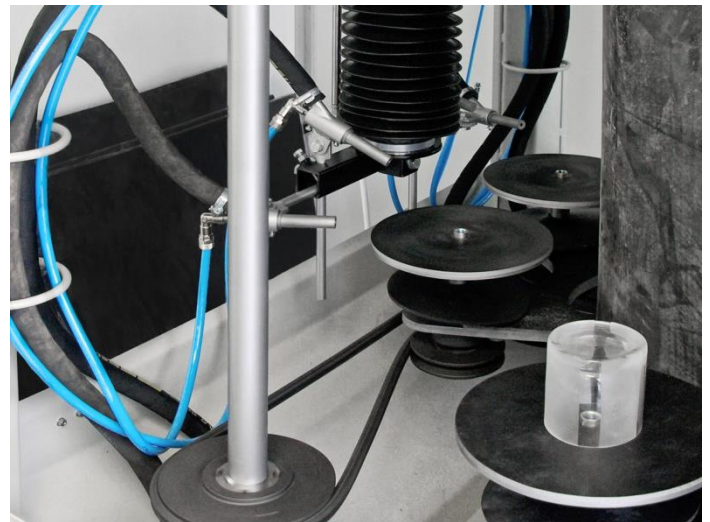

This device is suitable for blasting of large amount of products that are of rotatory shape, especially for fine blasting (sweeping) of metals or matting glass (glasses, vases etc.)

Carousel 1200-20

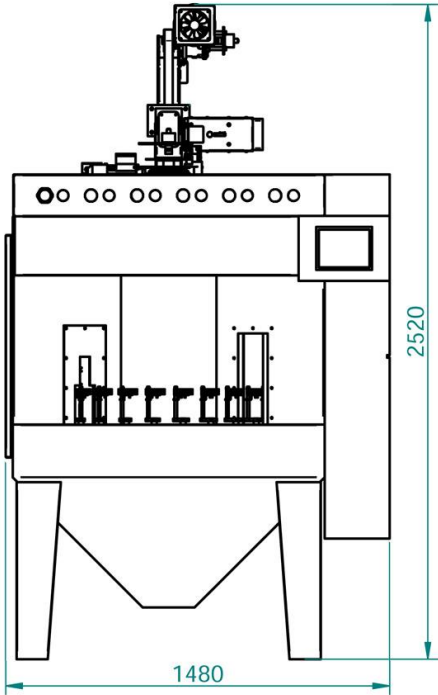

Outer dimensions (aprox)
width 1480 mm
depth 1330 mm
height 2520 mm

It is provided in **injector** version.

An example of carousel blasting machine with 20 planetary stations. The device is controlled by touch screen which enables exact setting of specific parameters.

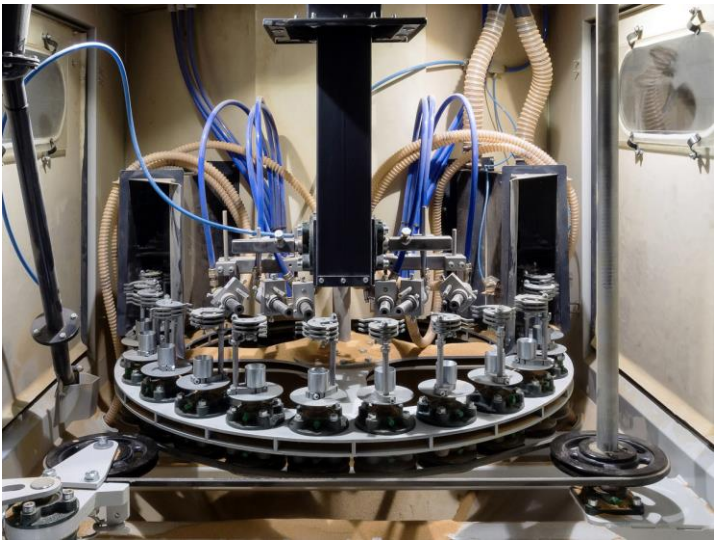

TB 225-RT Automatic Blast Cabinets with Turntable

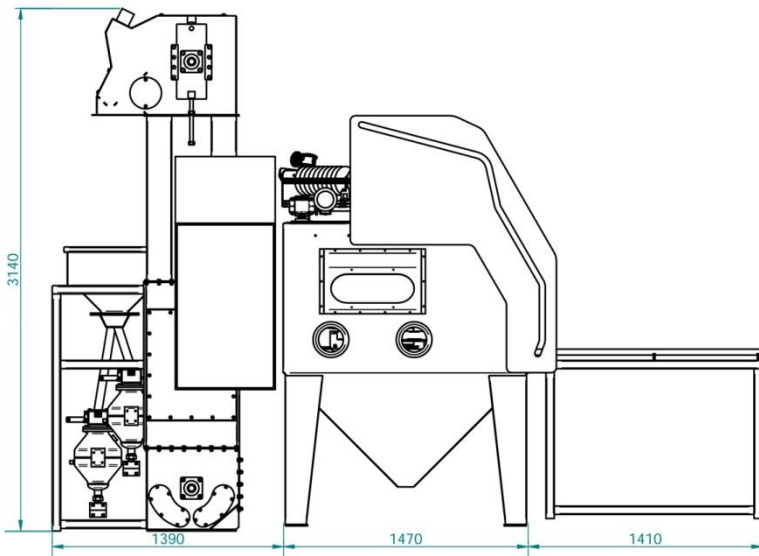

Outer dimensions (aprox)
width 4270 mm
depth 1610 mm
height 3140 mm

This cabinet serves for blasting of rotatory components of larger diameters. It has rolling-out turntable with trolley (which is optional). It is equipped with movable nozzles and (up to) three pressure units. According to blasting media cabinet may be used for standard blasting, shot peening or non-invasive cleaning. Elevator or pneumatic unit may be used for transport of media. Manual workplace is optional as well.

Touch screen allows setting and loading appropriate program for each particular product and setting authorization (operator, supervisor, maintenance...)



SCM v.2

Here we are dealing with non-abrasive (non-invasive) soft cleaning. Abrasive media used in 'Screw Cleaning Machines' are those which do not damage the surface of blasted components.

Depending on the requested level of cleaning, type and size of a screw, an operator sets an individual program. The cleaning process itself is then fully automatic and operator is free to work on something else in the meantime. If an operator finds further cleaning necessary when checking the result, he can choose an additional program or spot cleaning via remote control.

Screw cleaning machines are controlled on a touch screen which allows setting several levels of authorization such as operator, supervisor, and maintenance.

The machine is standardly provided with workplace safety equipment e.g. photoelectric sensor etc.

With other abrasive material the machine can be used for shot peening or for blasting rods (shafts, bolts, cylinders).

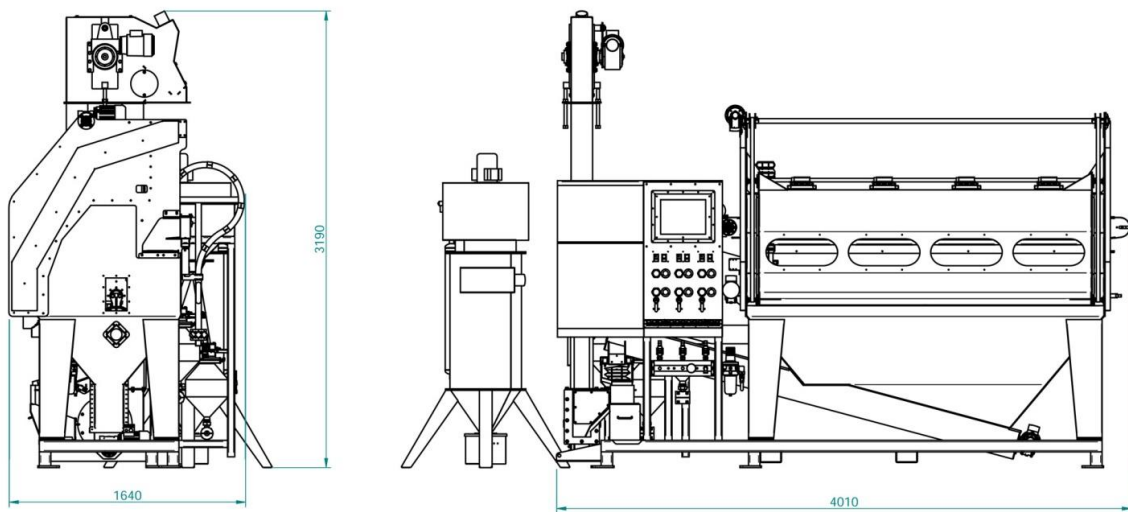

Outer dimensions (aprox)

width	4010 mm
depth	1640 mm (including nozzle arm)
height	3190 mm (including elevator)



Pneumatic blasting rooms

Pneumatic blasting rooms are solutions for blasting of objects too large for cabinets with operator working from outside. Here operator works inside the blasting room dressed in special coveralls with air supply respiratory equipment. Our blasting rooms meet all the ecological and hygienic requirements. Usually, they are provided with systems for collecting, cleaning, and delivering abrasive material back into the cycle. Thanks to their efficiency and power they represent one of the most economical ways of manual blasting.

Their size usually ranges from 4 x 3 m up to a few dozen meters. During construction we use standardized items, but every one of the practical applications is adjusted to the client's requirements. As to abrasive collection systems, we prefer so called scraper floor recovery system which has the lowest possible construction preparation costs.

For some applications, e.g. glass beading we supply rooms with pneumatic collecting and transportation of abrasive material. It is possible to use various materials, however a steel grit is the most common type of abrasive for pneumatic blasting rooms.

We supply all the equipment and protectives to blasting rooms, such as coveralls, helmets etc.

TBK Combi Cabinet

We have developed a special cabinet called "Combi cabinet" with size cca. 4 x 3 m and its own heightened supporting frame. Therefore, no extra construction work in the foundations is necessary. On top of that an operator may work both outside and inside the "Combi cabinet"

TBK 1103

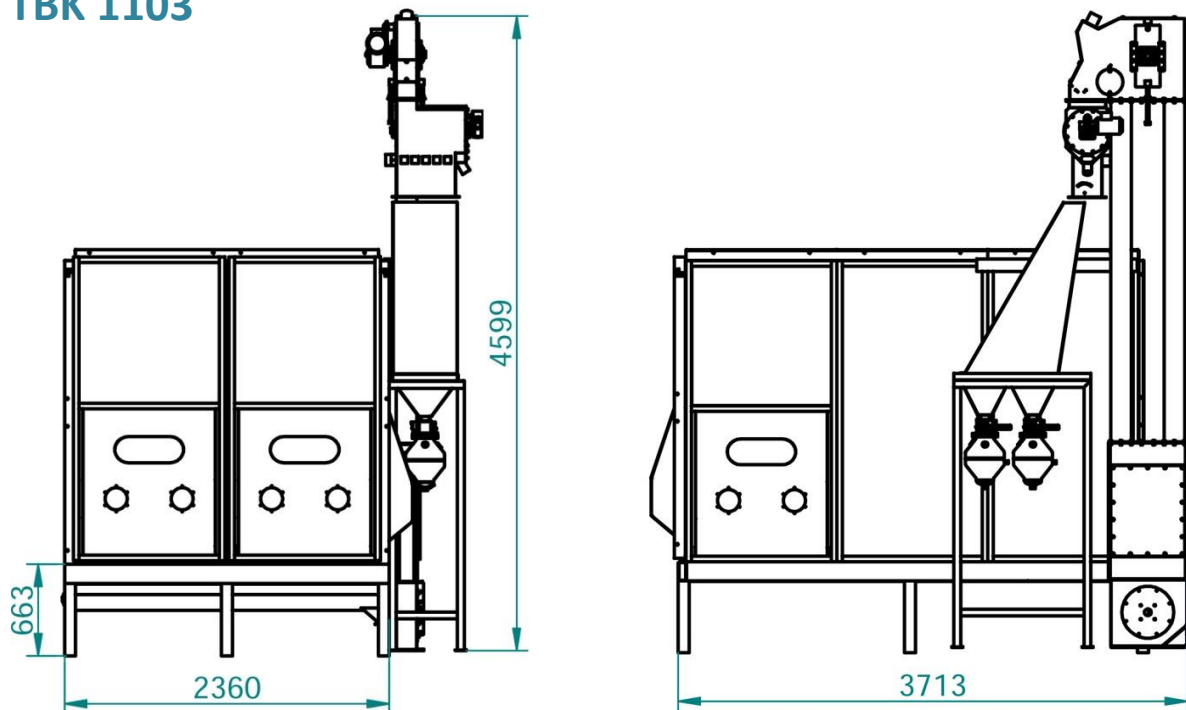

Inner dimensions (aprox)	
width	2150 mm
depth	3600 mm (including nozzle arm)
height	2150 mm (including elevator)

Combi cabinet is designed primarily for blasting with an operator inside. However it can be combined with one or more workplaces to enable blasting from outside. Cabinet in the picture is equipped with scraper floor recovery system, reservoir, elevator with abrasive cleaner and two 10-litre pressure units.

TBK 1104

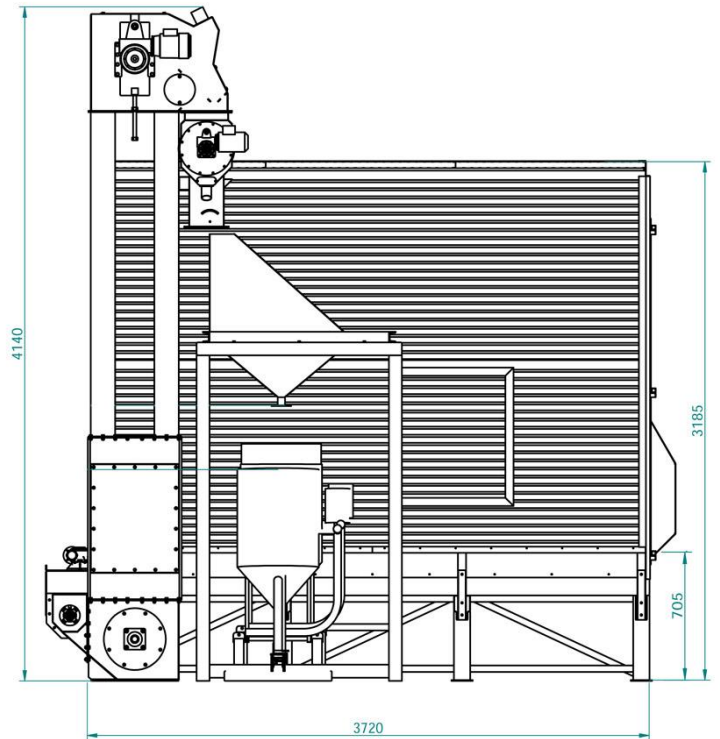
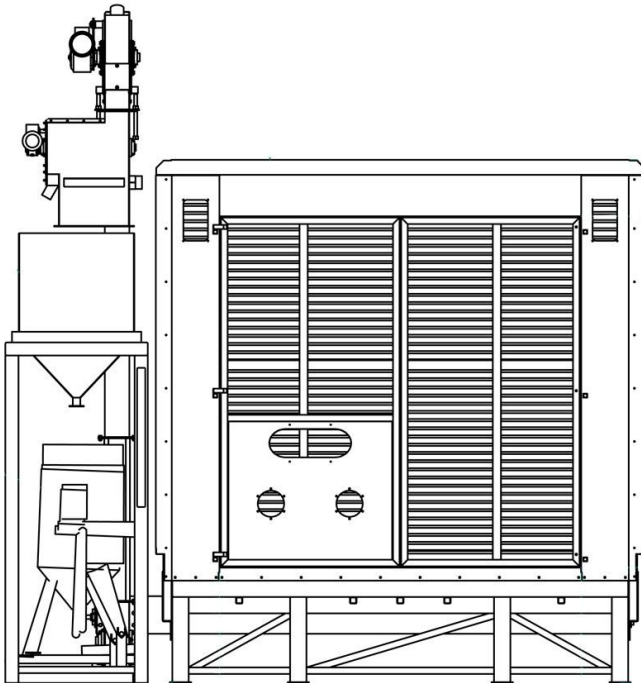

Inner dimensions (aprox)
width 2800 mm
depth 3700 mm
height 2150 mm

Combi cabinet is designed primarily for blasting with an operator inside. However it may have even more workplaces which enable blasting from outside. In the picture you can see cabinet equipped with scraper floor recovery system, reservoir, elevator with abrasive cleaner and a 70-litre pressure unit.



Combi cabinet TBK 1103

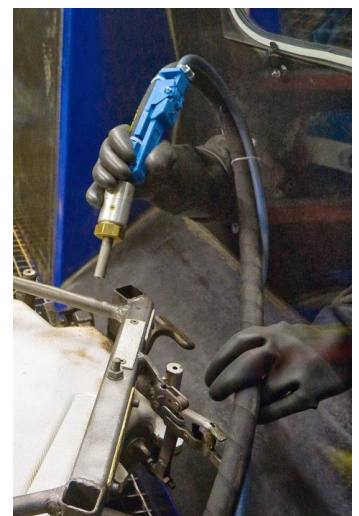

Blasting from outside

Blasting Rooms with Full Floor Scraper Recovery System

Significant advantage of this kind of blasting rooms are the lowest possible construction preparation costs. Their size and design vary depending on customers' request. The abrasive circulation is closed (scrapers, cross screw conveyor, elevator, abrasive cleaner, reservoir, blasting unit). Steel grit is the most common type of abrasive used in blasting rooms.

The configuration is individual according to requests.



Blasting room 10x5 meters with carrier trolley and overhead C track (up to 1t), scraper floor recovery system.



Blasting room 10x5 metres with carrier trolley and overhead C track (up to 300kg), scraper floor recovery system.

Blasting Rooms with Screw Partial Recovery System

This simplified version has only single screw conveyor (placed under floor level) and the operator sweeps abrasive manually. It is suitable for smaller rooms and mineral abrasive. The abrasive circulation is closed (cross screw conveyor, elevator, abrasive cleaner, reservoir, blasting unit).



In the groove covered with grid there is a screw conveyor for mineral abrasive.



Detail.

Blasting Rooms with Pneumatic Transport

Mineral abrasives are most suitable for this kind of blasting rooms. Pneumatic transport enables both fast cleaning and exchange of abrasive. Process of cleaning takes place during circulation. There are three variants for abrasive recovery system: floor suction with extender, partial suction groove (see pictures above), full area suction.

The configuration is individual according to requests.



Double room 3x4 m allows blasting with two kinds of abrasives at the same time (e.g. corundum and glass beading).



Blasting room interior with pneumatic suction.



Pneumatic suction with extender



Room 3x3m with whole area suction and double external abrasive transport unit. Lever switch enables fast exchange of abrasive, e.g. corundum vs glass beads. Each abrasive has a cleaner and a reservoir of its own.



Pneumatic abrasive transport unit providing exchange of material within one blasting room. When one kind of abrasive is sucked into an appropriate reservoir the device switches from this one to another (in this case from corundum to glass beads).



Interior with pneumatic recovery system.

Blasting Units with External Abrasive Delivery

Units with external abrasive delivery are applied to blast machines with pneumatic transport or to large cabinets (TTB 120 – 200), as it may become problematic to install the pressure unit directly under the hopper. Here we are dealing with a separate device equipped with pressure vessel, suction unit with filtration, reservoir and eventually cyclone. The device is connected to the machine and sucks spent abrasive from the bottom of the hopper. Refined abrasive is gathered in the reservoir, dosed back into the pressure vessel and used again. So the circulation is closed equally to standard design with pressure vessel under the cabinet. A special bonus, though, is a better quality of abrasive cleaning from dust particles.

BTS-3

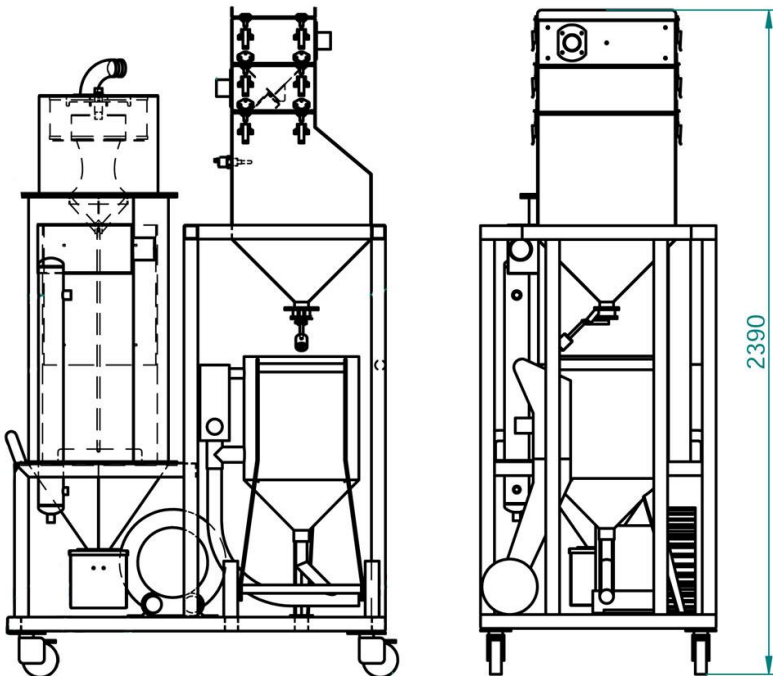

Outer dimensions (aprox)
width 1350 mm
depth 850 mm
height 2390 mm



Blasting unit with external abrasive delivery BTS-3 equipped with 40-litre pressure vessel

The unit may be equipped with pressure vessels of different size (from 10 to 40 litres)

With a special suction nozzle provided with brush preventing leakage of abrasive the unit can be used as a dust free vacuum blaster.

This configuration is applied for welded joints or external parts of pipelines.

Note: See next information about dust free vacuum blasters p.40

2TL

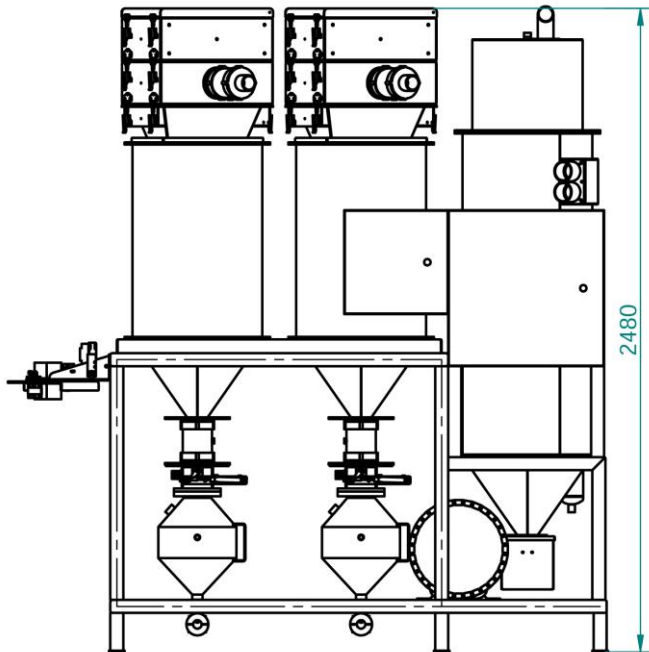

The unit may be equipped with pressure vessels from 10 to 16 litres.

Outer dimensions (aprox)
width 1350 mm
depth 850 mm
height 2390 mm

Possibility to change two abrasive materials is a great advantage of this device. Each material has a reservoir and a pressure vessel of its own, so that two different operations can be held in this cabinet - i.e. glass beading; the first operation is blasting with corundum and the second one is satening with glass (or ceramic) beads.

ZTZ - Sandblasting Marker

Sandblasting marker is used for large-scale marking (signing) of products, eventually for decorations not large in size. An operator attaches the product to the metal or rubber template which is fixed to an opening in an upper lid of marker. The sign is made by a short puls of abrasive. Time of the pulse and pressure of the air are adjustable. The device is controlled by pedal or by manual switch.

Sandblasting marker is a compact desk device with closed circulation of abrasive. The basic version is equipped with a dust filter. We recommend to connect vacuum cleaner (dust collector) to the marker. The main switch and control setting buttons are placed on a control panel.

Sadblasting marker is supplied in single or double version.

The effective blasted area can be extended up to 20 mm. Products of various shapes can be signed by using of an appropriate head.

Note: The device is supplied without a shaped head and without a template which are specially designed for a particular product.



Marker ZTZ-2 Double enables to work using both hands and to increase the effectivity remarkably.



Given version is controlled by a pedal but manual switch control is optional as well.

Outer dimensions (aprox)

	Single	Double
width	310 mm	640 mm
depth	310 mm	310 mm
height	600 mm	600 mm



Sandblasting marker ZTZ-1 Single

Microblaster

A special blaster with a small pressure vessel and a nozzle up to 2 mm. It is convenient especially for intensive local blasting or when two-material use is necessary. The device is successfully applied in toolrooms, laboratories, glass production, decorative sandblasting, dentistry, prosthetics and museum management.

According to the small nozzle diameter new or sorted abrasive material has to be used in this device.

Microblaster is often used as a supplementary equipment for injector blasting cabinets. Spent material is added to the injector circulation.



Microblaster has to be filled with new or sorted abrasive. There is a lever for filling in the picture. By pushing the lever a doze of abrasive is fed into container.



Microblaster is often used as a supplementary equipment for injector blasting cabinets. It is fastened from the side or on the front leg of the cabinet.

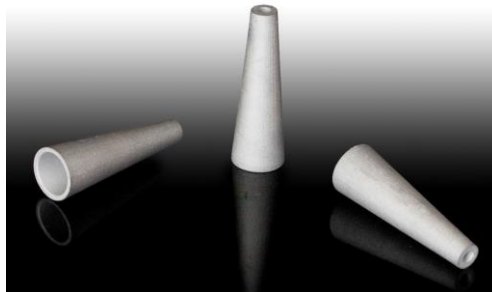

2 mm nozzles for microblaster.

Blast Pots

We provide these mobil units with pressure unit ranging from 10 to 200 litres. Smaller units are suitable mostly for maintenance work, minor construction repairs and other smaller operations. One of the huge advantages of blast pots is its mobility and easy transportability. Standard equipment of these machines is remote control, which guarantees safe operation. Every unit, regardless its size, goes with abrasion-resistant hoses.



TTJ 10

TTJ 10 is the smallest professional blasting unit. It is equipped with 10-litre pressure vessel (optionally 12 or 16 litres) and with 5-7 mm nozzles. The performance is as high as it is in large machines when operating with nozzles of the same size. Both filling and blasting time are shorter according to the smaller volume of the vessel.

Used in building industry, metal production, automotive industry, glass production and woodworking.

Outer dimensions (aprox)	width:	450 mm
	depth:	600 mm
	height:	1000 mm
Empty weight aprox:		28 kg
Pressure vessel volume:		10 litres
Abrasive batch:		8 litres
(i.e. aprox 10 kg of mineral abrasive or 35 kg of steel grit)		

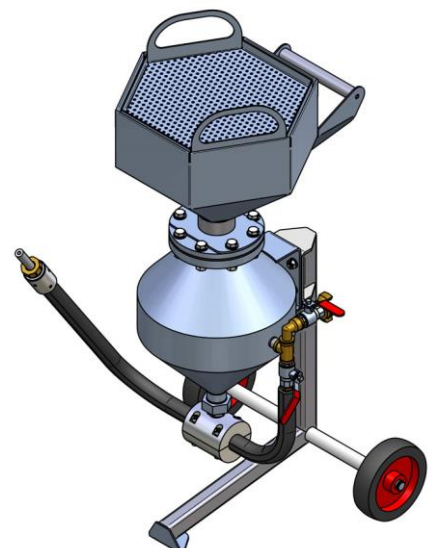

Unit TTJ is a base for a line of modifications.

TTJ 10-2

TTJ 10-2 serves as an additional mobile unit to working places situated in establishment. It is fitted in a frame with four wheels to be easily manipulated. It may be controlled by a pedal.

Outer dimensions (aprox)	width: 450 mm
	depth: 800 mm
	height: 1100 mm
Empty weight aprox:	35 kg
Pressure vessel volume:	10 litres
Abrasive batch:	8 litres
(i.e. aprox 10 kg of mineral abrasive or 35 kg of steel grit)	



TTJ 10 with Irrigation Head

During blasting the water is added to the mixture of abrasive and air, the moist dust doesn't disperse to the surroundings. This configuration is convenient for cheap disposable abrasives, i.e. copperslag or sand (according to hygienic regulations in particular countries). The material has to be dried when reused.

Used mostly in building industry for cleaning brick walls to get rid of remaining plaster, cleaning statues or stairs, matting stone slabs, blasting through the template etc.



Dust Free Vacuum Blasters

Vacuum blasters with closed abrasive delivery system are in fact special blast pots. These are used for blasting of workpieces which are not removable, or for blasting in premises where it is essential to avoid dusting. The nozzle is surrounded by a suction head preventing leakage of abrasive which is sucked back into the container.



BTS-3 is a unit with external abrasive delivery (see page 34). If it is equipped with a suction head it can be used as a dust free vacuum blaster. Due to its large pressure vessel it is suitable for blasting large surfaces.

Outer dimensions (aprox)

width	1350 mm
depth	850 mm
height	2390 mm

The device needs compressed air and 380V electricity supply.



TTJ 10 as a dust free version. Industrial vacuum cleaner provides sufficient vacuum for exhaustion of abrasive material. The great advantage of the device is its low weight (about 40 kg) and easy transportability when dismantled.

Outer dimensions (aprox)

width	450 mm
depth	800 mm
height	1900 mm

The device needs compressed air and 220V electricity supply.

High Volume Blasting Pots

We provide high volume units ranging from 40 to 200 litres.

TTJ 40

This unit isn't too large and so it is possible to handle it quite easily. It is suitable for blasting of rugged items and is equipped with 5 - 9 mm nozzle and 5 - 20 m hoze.

Outer dimensions (aprox)	width: 600 mm depth: 750 mm Height: 1000 mm
Empty weight cca:	50 kg
Pressure vessel volume:	40 l
Max. pressure:	10 bar
<i>Note. These units may be provided with an additional hopper, a sieve and a lid.</i>	

TTJ 100

This large unit is suitable for blasting sizable items. It is equipped with 7- 10 mm nozzles and hoses up to 80 m.

Outer dimensions (aprox)	width: 800 mm depth: 950 mm Height: 1160 mm
Empty weight cca:	75 kg
Pressure vessel volume:	100 l
Max. pressure:	10 bar
<i>Note. These units may be provided with an additional hopper, a sieve and a lid.</i>	



TTJ 200

The largest unit is suitable for blasting sizable items. It is equipped with 7- 10 mm nozzles and hoses up to 80 m.

Outer dimensions (aprox)	width: 800 mm depth: 1100 mm height: 1475 mm
Empty weight cca:	113 kg
Pressure vessel volume:	200 l
Max. pressure:	10 bar
<i>Note. These units may be provided with an additional hopper, a sieve and a lid.</i>	

We can provide all necessary working equipment and protectives, such as helmets, air-conditioners etc.

Dust Collectors

These devices serve for exhaustion of dust emerging from the blasting process. It is necessary to change the whole air volume per one minute. Required performance and number of cartridges depend on the size of a blasting machine. Conical cartridges which are used in our dust collectors are regularly and automatically cleaned by air pulse. Filtering fabric may be made of paper, plastic or with a layer of PTFE. Besides the delivery of a blaster we always offer the most appropriate type of a dust collector.

KOP 1

Dust collector for cabinets TB 70 – TB 90. This device is firmly fastened to the cabinet.

Power consumption:	0,37kW
Number of cartridges:	1 Ks
Cartridge surface:	2,3m ²
Volume of exhausted air:	600m ³ /575Pa

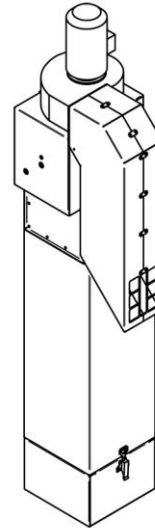

OFJ 1

Dust collector for cabinets TB 120 - TB 200, combi cabinets and automatic blasting machines.

It is produced in two versions: standard v. with cartridge surface 10m² and extended v. with cartridge surface 16m².

Dimensions (aprox):	
width:	895 mm
depth:	895 mm
height OFJ 1S:	2220 mm
height OFJ 1L:	2630 mm

Power consumption:	0,55 kW
(variants)	1,1kW
	2,2 kW

Numer of cartridges:	1 Ks
Cartridge surface OFJ 1S:	10 m ²
Cartridge surface OFJ 1L:	16 m ²

Volume of exhausted air depending on the power consumption:	0,55kW	500m ³ /1500Pa
	1,1kW	900m ³ /1500Pa
	2,2kW	2000 m ³ /1500Pa (3000 m ³ /800Pa)

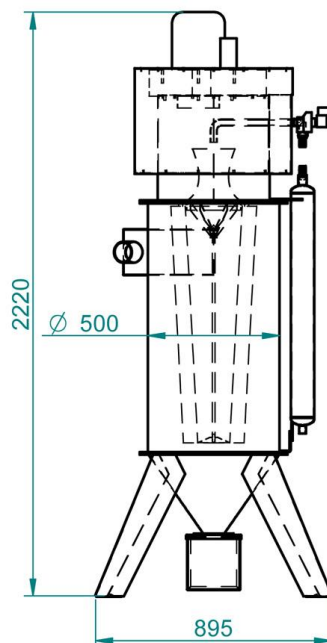

OFJ 2

Dust collector for cabinets TB 120 - TB 200, combi cabinets and automatic blasting machines.

Dimensions (aprox):

width:	895 mm
depth:	895 mm
height OFJ 2S:	2220 mm
height OFJ 2L:	2630 mm

Power consumption: 2,2kW

Number of cartridges: 2 Pc

Cartridge surface OFJ 2S: 20 m² (2x 10 m²)

Cartridge surface OFJ 2L: 32 m² (2x 16 m²)

Volume of exhausted air: 2000-3200 m³/1800Pa

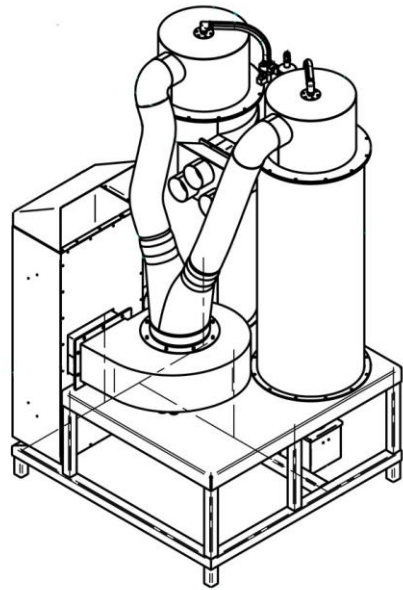

OFJ 3

Dust collector for combi cabinets and blasting rooms.

Dimensions (aprox):

width:	1600 mm
depth:	635 mm
height:	2650 mm

Power consumption: 3kW

Number of cartridges: 3 Ks

Cartridge surface: 30 m² (3x 10 m²)

Volume of exhausted air: 2500m³/1500Pa

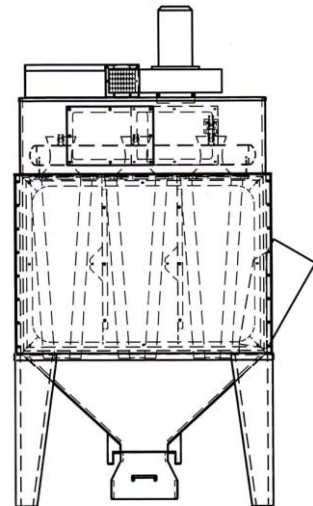

OFJ 6 (503-6P)

Powerful dust collector for combi cabinets and blasting rooms.

Dimensions (aprox):

width:	1380 mm
depth:	885 mm
height:	2250 mm

Power consumption:

External ventilator 4kW nebo 7,5kW

Number of cartridges: 6 Ks

Cartridge surface: 60 m² (6 x 10 m²)

Volume of exhausted air depending on the power

consumption: 4kW 3000m³/2000Pa

7,5kW 7500 m³/3000Pa

(6000 m³/4000Pa)

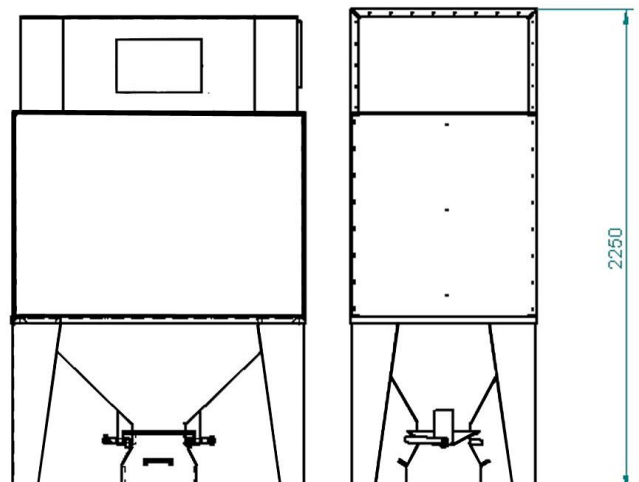

Blast Media

The choice of the right abrasive is a fundamental part of the whole process. Therefore an overview of the most frequent kinds of abrasives and the sphere of their use is mentioned here.

Steel Grit

Steel grit is one of the most common materials used in closed cycled blasting machines: blast cabinets and blast rooms. It is advantageous especially for pressure blast machines and is used for blasting of iron materials, for rust and dross removal, for pre-treatment of powder coating, painting and electroforming. Steel grit is a highly efficient and cost-effective material.

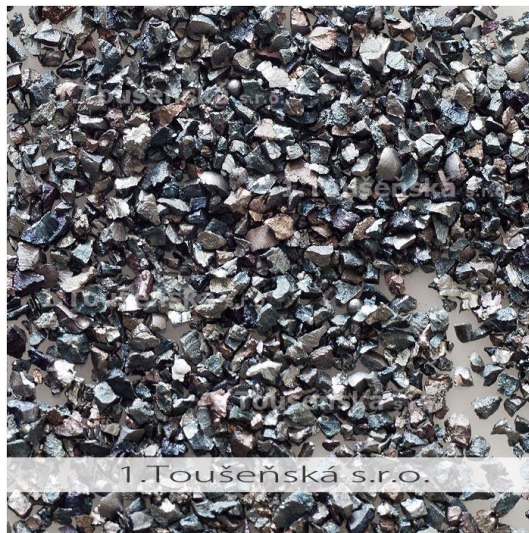

Steel Grit

Cut Wire Shot

Cut wire shot is sometimes being used instead of steel grit. However, steel grit is of higher efficiency. Cut wire shot is also available from non-ferrous materials such as brass, zinc, or stainless steel.



Cut Wire Shot

Cast Steel Shot

Cast steel shot is used similarly as steel grit in mechanical blasters with wheel blast units. In pneumatic cabinets, this abrasive serves for **Shot Peening** – hardening process of stressed components, which thickens a surface layer and increases its service life. (gears, shafts, springs, etc.).

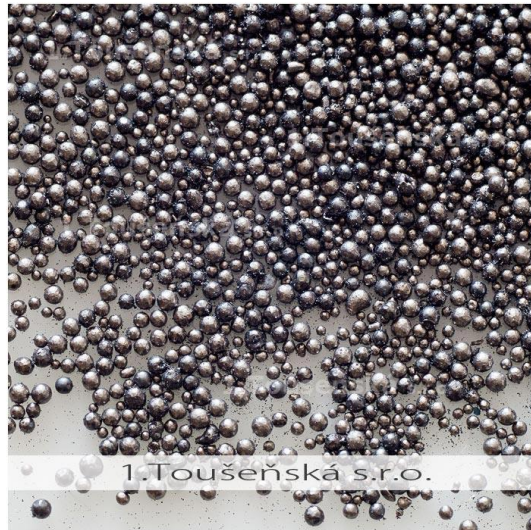

Cast Steel Shot

Corundum (Aluminium Oxide)

Corundum is typically utilized for sharp-edged blasting of non-ferrous metals where it is essential to avoid iron contamination of the surface. In other words, aluminium oxide is suitable for stainless steel, aluminium, brass, and galvanized iron. There are several advantages of corundum use: first, it is its high cleaning efficiency as it splits during the blast process and so always creates sharp edges; second, it is its wide range of granularity, especially in combination with injector blast system, which guarantees perfect regulation of final surface treatment and enables even blasting of very thin metal sheets. Corundum works as a pre-treatment stage or as a first stage of glass bead blasting (satining).

Note: It is supplied in two versions: white or brown.



White Corundum

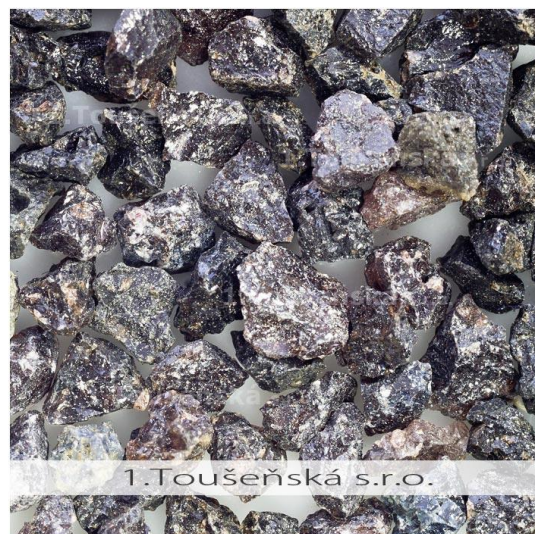

Brown Corundum

Garnet

What has been said about corundum can be basically applied to garnet as well. Nevertheless, garnet, unlike synthetic corundum, is a natural product and as such is supplied in lower number of granularity. On the bright side, the costs are also usually lower.



Garnet

Glass Beads

Glass beads for blasting of non-ferrous metals are used either as a final treatment or as a pre-treatment for anodic oxidation of aluminium surface or galvanization. The surface gains elegant satin look which also lowers visibility of any potential damage.

The best results are reached in a so called two-stage process. Firstly, the surface is cleaned and unified by sharp-edged abrasives (corundum or garnet); secondly, the gleam is once again restored by glass blasting beads. These are supplied in number of granularity. By a combination of both stages and appropriate pressure it is possible to control the final appearance of a product to a great extent.

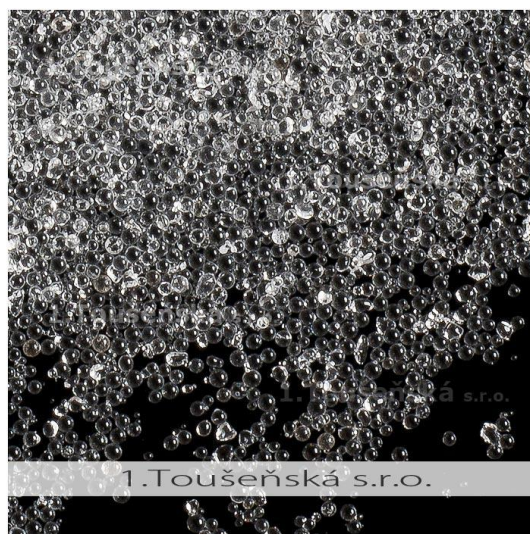

Glass Beads

Click on www.balotinovani.com/en/ for more information and photos of application.

Ceramic Shot Beads

Ceramic shot beads are of similar use as glass beads. However, thanks to their hardness they have better lifespan and as such can be even used for treatment of very hard stainless steel. They are supplied in a large scale of granularity.

Walnut Shell

Crushed shells are used for cleaning of workpieces whose surface must not be damaged or hardened. They are supplied in a large scale of granularity.



Walnut Shell Blast Media

Plastic Beads

Plastic beads are synthetic product with similar employment as walnut shell blast media. It is supplied in a large scale of hardness and granularity.



Plastic Beads

Silica Sand

Historically oldest blast medium was used especially in mobile sand blasting for its low costs and high effect. Nevertheless, nowadays this abrasive medium is not being used, except from rare cases. Silica sand is not recommended, actually it is forbidden in many countries (including the Czech Republic). The reason is that it is the only blast medium which causes an illness, silicosis. Such a danger does not occur with any other blast media.

Blast Furnace Slag

Blast furnace slag nowadays substitutes silica sand in mobile blasting.

For special purposes other materials such as stainless beads, aluminium or zinc cut wire shot, brass grit etc. are also being used.

The manufacturer reserves the right to change design or technical and performance parameters.

Registered Office:
1.Tousenska s.r.o.
Resetovska 855
193 00 Praha 9-Horni Pocernice
Czech Republic

Main Plant:
1.Tousenska s.r.o.
Hlavni 91
250 89 Lazně Tousem
Czech Republic

RegNo: 25789066
VAT: CZ25789066

E-mail: info@1tousenska.cz
Web: www.sandblastingmachines.eu

Company is registered at the City court of Prague, under mark C70378, file number 57186/99